

Upholstery Replacement Instructions

To remove cover

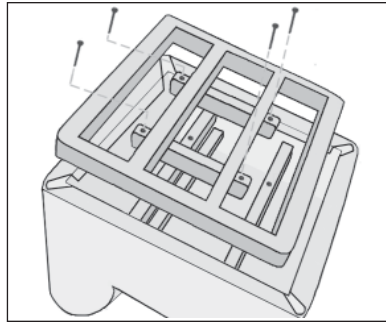

1 Place chair upside down, remove base (PB) or glides (FF).

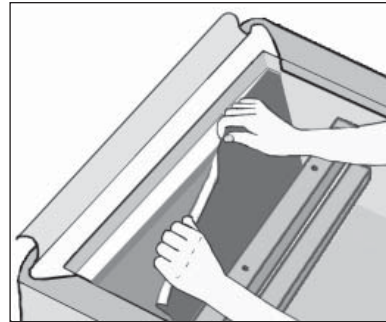

2 Release velcro on sides, front, back and inside back. Slide cover up over corners.

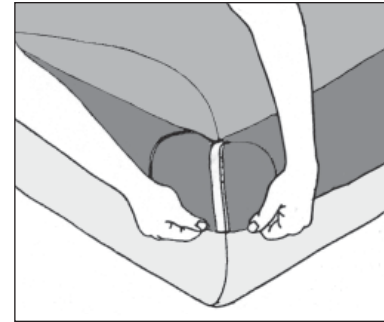

3 Turn unit upright. Slide cover up back, up over seat.

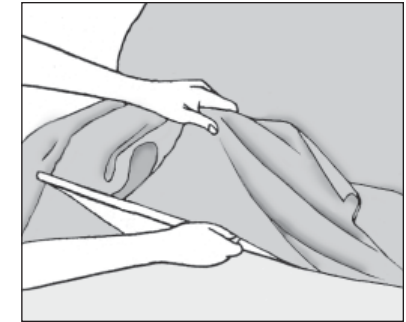

4 Carefully pull casing out from between seat and back. Repeat for additional casings of corner sections.

To replace cover

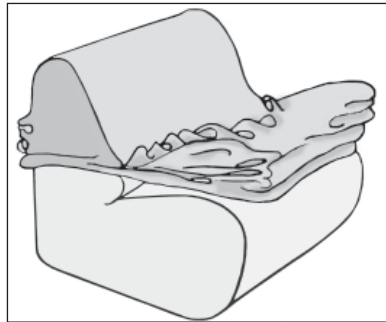

1 Put cover on upper back, seat facing forward to match side profile.



2 Smooth fabric down over upper back to seat.

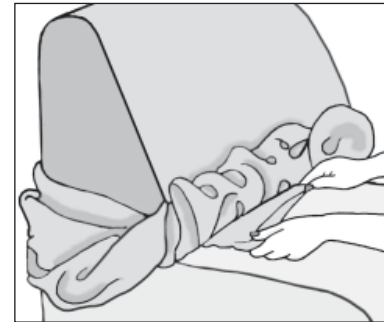

3 Push seat casing thru opening between upper back and seat. Repeat for corner units.

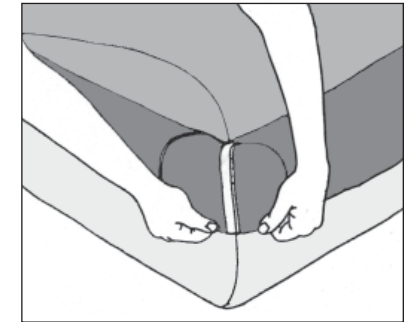

4 Smooth fabric down back, seat, sides. Turn unit over and attach velcro of seat casing to inner back cross rail.

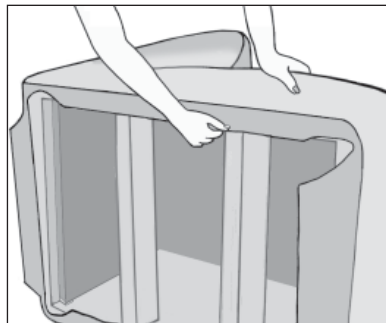

5 Smooth fabric down on all sides.

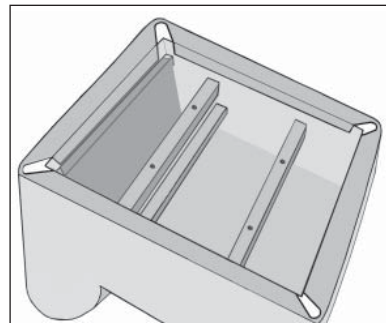

6 Attach sides, front, and back velcro hems.

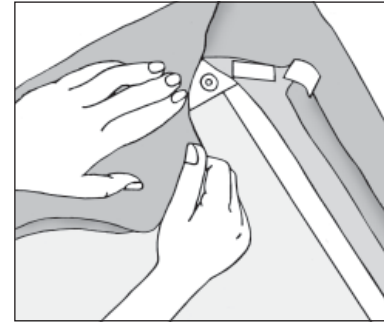

7 Adjust corners for smooth fit around openings.

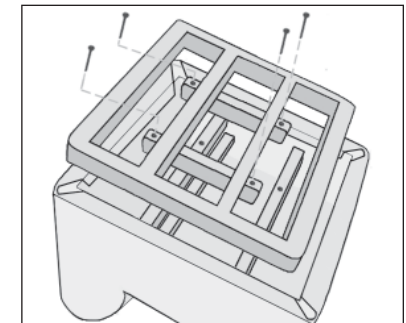

8 Replace plinth base for PB units; replace glides for FF units.